

SONICATOR®

ULTRASONIC LIQUID PROCESSOR

OPERATION MANUAL



MODELS

XL2020

XL2015

XL2010

MISONIX INCORPORATED
1938 New Highway, Farmingdale, NY 11735 U.S.A.

Telephone: 631-694-9555 Fax: 631-694-9412

Toll Free: 1-800-645-9846

www.misonix.com

TABLE OF CONTENTS

1.	Safety - Warnings and Precautions	1-1
2.	Getting Started	2-1
	Inspection	2-1
	Power Requirements	2-1
	Placement of Equipment	2-1
	System Components Diagram	2-2
3.	Specifications for XL2020, XL2015 & XL2010	3-1
4.	Description of Major Components	4-1
	Generator (Power Supply)	4-1
	Process Control Features of Model XL2020	4-1
	Process Control Features of Model XL2015	4-1
	Convertor (Transducer)	4-2
	Horn (Probe)	4-2
	Replacement Flat Tips	4-2
5.	Function of Controls and Indicators	5-1
	XL2020 Functions	5-1
	XL2020 Controls and Indicators Diagram	5-2
	XL2010 & XL2015 Functions	5-3
	XL2010 & XL2015 Controls and Indicators Diagram	5-4
6.	Preparation for Use	6-1
	Convertor Mounting Diagram	6-2
	Removal and Attachment of Horns and Tips	6-3
	Removal and Attachment of Horns and Tips Diagram	6-4
7.	Tuning Instructions	7-1
	XL2020 Tuning Instructions (Probes & Horns)	7-1
	XL2010 & XL2015 Tuning Instructions (Probes & Horns)	7-2
	Microtip™ and Cup Horn Instructions	7-3
8.	Programming the Microprocessor of XL2020	8-1
	Review of Keys	8-1
	Keypad Diagram	8-1
	Continuous Mode	8-2
	Timer Mode Only	8-3
	Pulsar™ Mode Only	8-4
	Timer and Pulsar™ Mode	8-5
	Storing Programs into Memory	8-6
9.	Accessories	9-1
	Cup Horn	9-1
	Installation	9-1, 9-2
	Operation	9-2
	Output Setting Parameters	9-2
	Maintenance	9-3
	Continuous Flow Cell	9-3, 9-4
	Microtip™	9-5

	Stepped Microtip™	9-5
	Extender Tip	9-6
	Sapphire Tipped Horn	9-6, 9-7
	Sonabox	9-7
	Dual Horn	9-7
	Tray Horn	9-7
	Sonabox Diagram	9-8
10.	Troubleshooting	10-1
	Overload Indicator Instructions	10-1
	Troubleshooting Guide	10-1
11.	Maintenance	11-1
	General Maintenance	11-1
	Cleaning Instructions	11-1
	Tip Care	11-2
12.	Applications	12-1
	Principle of Ultrasonics	12-1
	Processing Tissue	12-1
	Processing Difficult Cells	12-2
13.	Techniques	13-1
	Probe Depth	13-1
	Foaming and Aerosoling	13-1
	Viscosity Limitations	13-1
	Keeping Samples Cool	13-1
	Free Radical Formation	13-1
14.	Warranty	14-1
15.	Return of Equipment	15-1
16.	Literature Request	16-1
	Bibliographies	16-1
	Application Notes	16-1
	Published Papers	16-2
	Technical Notes	16-2
	Technical Bulletins	16-2

1. **SAFETY - WARNINGS AND PRECAUTIONS**

Read **ALL** Instructions Before Installing or Using Equipment

Your new Ultrasonic Liquid Processor has been designed, built and tested to assure maximum operator safety. However, no design can completely protect against improper usage which may lead to bodily injury and/or property damage. For total safety and equipment protection, read the instruction manual carefully before attempting to operate this equipment. Observe the following **WARNINGS**:

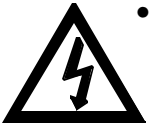

- High voltage is present in the generator (power supply), convertor and high frequency cable. There are no user-serviceable parts inside any of these devices. Do **NOT** attempt to remove the generator cover or convertor case.



- Do **NOT** touch any open cable connections on the unit while the power is turned ON.
- Do **NOT** operate generator with convertor disconnected from high voltage cable. High voltage is present in the cable and may pose a shock hazard.
- The generator must be properly grounded with a 3-prong plug. Test electrical outlet for proper grounding before plugging in unit.
- Install the SONICATOR® in an area free from excessive dust, dirt, explosive or corrosive fumes and protected from extremes in temperature and humidity.
- **NEVER** immerse the convertor in liquids of any kind, or let condensed moisture or liquid drip into the convertor.
- **NEVER** grasp an activated horn or touch the tip of a vibrating probe. It can cause severe burns and tissue damage.
- **NEVER** hold or clamp the convertor by the front driver (black portion) or by the horn itself. This can cause permanent damage to the system. Support the convertor by clamping only around the broad (chrome) section.
- Do **NOT** allow the tip of a vibrating horn or probe touch the counter top or any other hard surface. It could damage the probe or overload the generator.
- Avoid touching the bottom or sides of a glass or plastic container with a vibrating probe. It could crack or shatter the glass or melt the plastic.
- Turn **OFF** the power switch, unplug the generator and disconnect the power cord from the back of the generator before attempting to replace the fuse.

2. GETTING STARTED

INSPECTION

Your new SONICATOR® Ultrasonic Liquid Processor was thoroughly inspected, tested and carefully packed before leaving the factory. Prior to unpacking, carefully inspect the shipping carton for any evidence of damage. Claims for loss or damage sustained in transit, must be made to the shipping company.

Unpack the unit from its shipping carton and check the contents against the packing list. Before disposing of the packing material, check it carefully for small items. Report any missing components to Misonix immediately.

Visually inspect all external controls, indicators and surfaces to detect any damage in transit. If damage has occurred, contact your carrier within 48 hours of delivery date. **DO NOT OPERATE DAMAGED EQUIPMENT.** Retain all packing materials for possible future shipments.

POWER REQUIREMENTS

For power requirements, check the label on the back of the unit.

1. For 110V operation, the generator requires a single phase, three wire, 110V, 50/60 Hz line supply, unless otherwise specified.
2. For 220V operation, the generator requires a single phase, three wire, 220V, 50/60 Hz line supply, unless otherwise specified.

WARNING!!

The electrical line cord is equipped with a 3-prong grounding plug. Do not, under any circumstances, remove the grounding prong. The plug must be plugged directly into a mating 3-prong grounding type outlet.

PLACEMENT OF EQUIPMENT

Place the Generator in an area that is free from excessive dust, dirt and explosive or corrosive fumes. A fan maintains safe operating temperature in the generator by circulating air over the electronic components. Therefore, the generator must be placed so that the air intake on the rear panel is not blocked. Clean and inspect the air intake grill periodically, to insure it is free from dust and debris.

3. SPECIFICATIONS FOR XL2020, XL2015 & XL2010

<u>Generator</u>	<u>110 Vac</u>	<u>220 Vac</u>
Input Voltage	100-130 Vac @ 50/60 Hz	200-260 Vac @ 50/60 Hz
Full Load Current	10 Amps	7.5 Amps
Fuse Rating	10 Amps (GDB10)*	8 Amps (GDB8)*
Weight	14 lbs. (6.3Kg)	16.5 lbs. (7.4Kg)
Dimensions	7.5"x18.5"x11.6" (WxLxH) 19cm x 47cm x 29.5cm	7.5"x18.5"x11.6" (WxLxH) 19cm x 47cm x 29.5cm
Output Voltage	1500 V rms (max.)	1500 V rms (max.)
Output Frequency	20 KHz (nom.)	20 KHz (nom.)

<u>Convertor</u>		
Weight	2 lbs. (0.9 Kg)	2 lbs. (0.9 Kg)
Dimensions	8" L x 2.5" Dia. (20.3cm x 6.4cm)	8" L x 2.5" Dia. (20.3cm x 6.4cm)
Materials	Aluminum	Aluminum

<u>Standard Horn</u>		
Weight	0.5 lbs. (0.45Kg)	0.5 lbs. (0.45Kg)
Dimensions	5" L x 1.5" Dia. (12.7cm x 3.8cm)	5" L x 1.5" Dia. (12.7cm x 3.8cm)
Materials	Titanium Alloy	Titanium Alloy

<u>Environmental</u>		
Pollution Degree	Two (2)	Two (2)
Installation Category	II	II
Temperature Limits	50 F to 110 F (10 C to 43 C)	50 F to 110 F (10 C to 43 C)
Barometric Pressure	Unlimited**	Unlimited**

* Only use IEC approved fuses, model GDB10 for 110V and GDB8 for 220V. Do NOT use "slow blow" fuses or fuses rated above the amperage noted.

** In a Vacuum area, additional cooling provisions may be needed.

ACCESSORIES

Use only accessories and probes listed in the Misonix catalog as suitable for use with this equipment. Do **NOT** attempt to fabricate ultrasonic tooling or accessories unless approval has been obtained from Misonix in advance.

4. DESCRIPTION OF MAJOR COMPONENTS

GENERATOR (POWER SUPPLY)

Includes all operating controls and indicators, detachable three-wire grounded line cord, fuse, external power control jack and high frequency cable connector.

PROCESS CONTROL FEATURES OF MODEL XL2020

- **Microprocessor Controller** - allows precise control of output power, elapsed processing time, and cyclical rates of power pulsing. It encompasses the functions of the Digital Integrating Timer and the Multi-Range PULSAR™ Cycle Timer.
- **Digital Integrating Timer** - permits precise timing of ultrasonic energy applied in one second increments from one second to ten hours. The total desired processing time is set on a pressure-sensitive keypad. Both the processing time selected and actual total elapsed processing time is indicated by an LCD readout. A start/stop control initiates or reinitiates timed sonication. A pause control allows manual pulsing or delay. The total preset time of active sonication is unaffected by pauses or pulsing, whether by hand or with the Multi-Range PULSAR™ Cycle Timer.
- **Multi-Range PULSAR™ Cycle Timer** - permits the application of ultrasonic energy to the sample on a pulsed basis. Pulse on and off times are adjustable in 0.1 second increments from 0.1 seconds to 1 hour each. This intermittent operation permits high intensity sonication while avoiding heat build-up in the processed sample. It also allows particulate material being processed to settle back under the tip.
- **OVERLOAD INDICATOR** - under certain extraordinary conditions, the amount of power supplied to the convertor/horn assembly might endanger the circuitry of the generator to the point of failure. In order to prevent unnecessary downtime, an overload protection feature has been built into the generator. When the output power exceeds design specifications, the overload light will illuminate and the output will be disabled. The following prompt will appear: "OVERLOAD REFER TO MANUAL". (See 10-1 for instructions)

PROCESS CONTROL FEATURES OF MODEL XL2015

- **PULSAR™ Cycle Timer** - permits the application of ultrasonic energy to the sample on a pulsed basis. Energy is automatically set for one pulse per second. Pulse width adjusts smoothly from 0.05 of a second (5% duty) to 0.95 of a second (95% duty) every second. This intermittent operation permits high intensity sonication while avoiding heat build-up in the processed solution. It also allows material being processed to settle back under the tip.
- **OVERLOAD INDICATOR** - under certain extraordinary conditions, the amount of power supplied to the convertor/horn assembly might endanger the circuitry of the generator to the point of failure. In order to prevent unnecessary downtime, an overload protection feature has been built into the generator. When the output power exceeds design specifications, the overload light will illuminate and the output will be disabled. (If this should occur, follow instructions in 10-1)

CONVERTOR (TRANSDUCER)

Includes the electroplated housing, and black front driver (first stage of acoustic amplification) with a $\frac{1}{2}$ - 20 threaded hole for horn attachment. A separate high-frequency cable is also furnished.

HORN (PROBE)

A 5" L x 1½" W resonant body that steps down to a ½" diameter probe tip. The horn serves as the second stage of acoustic amplification. It includes a removable or solid tip, a ½ - 20 stud for attachment to the convertor and external threads around the body for attachment of accessories (e.g. Flow Cells). The Horn is available in three standard tip diameters of ½", ¾" or 1". In addition, each horn comes in three different tip configurations. Tapped horns have a replaceable Flat Tip; Solid horns do not have a replaceable tip; and Sapphire tipped horns have a 1/16" thick sapphire disk bonded to the tip of a solid horn.

REPLACEABLE FLAT TIPS

A ¼" thick, radiating surface attached to the end of the horn. The flat tips will erode with use and are replaceable. The tips are matched to horns of equal diameter (i.e. ½", ¾" or 1" diameter).

5. FUNCTION OF CONTROLS AND INDICATORS

XL2020 FUNCTIONS

POSITION NO.	CONTROLS	FUNCTION
1.	Process Time	Displays total pre-set time sonication is applied to sample (1 sec to 10 hours maximum).
2.	PULSAR™ ON Time	Indicates pulse ON time from 0.1 seconds to 1 hour.
3.	Power Output Display	Indicates relative percentage of maximum available ultrasonic power delivered to the horn (i.e. 40% output = 0.4 x 600 Watts available = 240 Watts delivered).
4.	PAUSE Indicator	Indicates that unit is being temporarily interrupted during processing.
5.	TIMER Indicator	Indicates that timer is set for processing.
6.	CLEAR Key	Clears previous or erroneous entries. Exits programming mode.
7.	ENTER Key	Enters data during program mode.
8.	Power Switch	ON Position (I) - energizes generator. OFF Position (O) - de-energizes generator.
9.	LCD Display Screen	Displays items 1, 2, 3, 10 & 11 listed below and prompts.
10.	Elapsed Time Display	Displays actual elapsed time of sonication.
11.	PULSAR™ OFF Time	Indicates pulse OFF time from 0.1 seconds to 1 hour.
12.	Overload Indicator	Indicates a load condition greater than the maximum output power of the generator or that the unit requires tuning or other readjustments.
13.	PULSAR™ Indicator	Indicates application of pulsed energy.
14.	PAUSE Key	Interrupts or Resumes processing cycle.
15.	TUNE Key	Activates or Deactivates tuning circuit.
16.	PROG/DATA Key	Initiates Timer and PULSAR™ entry program and displays entries on the LCD screen during run.
17.	START/STOP Key	Starts or Stops output in all modes of operation. Resets timer in timed mode.
18.	Amplitude Control Knob	Controls the amplitude of ultrasonic vibration at the tip of the horn.
19.	Tuning Control Knob	Allows adjustment of generator frequency to optimize performance of convertor/horn assembly. Also used to verify condition of horn and/or tip.
20.	SHV Cable Connector	Connects convertor cable to generator.
21.	Footswitch Jack	Connects external ON/OFF control (Foot Switch or Timer).
22.	Power Receptacle	Connects line cord to generator.
23.	Fuse (10 amp 115V) (8 amp 220V)	Protects against electrical overload.

XL2010 & XL2015 FUNCTIONS

POSITION NO.	CONTROLS	FUNCTION
1.	Overload Indicator	Indicates a load condition greater than the maximum output power of the generator or that the unit requires tuning or other readjustments.
2.	Tuning Switch	Activates tuning circuit.
3.	Power Switch	ON Position (I) – energizes generator. OFF Position (O) – de-energizes generator.
4.	Power Output Display	Indicates a <i>RELATIVE</i> percentage of maximum available ultrasonic power delivered to the horn (i.e. 40% output = 0.4 x 550 Watts available = 220 Watts delivered).
5.	PULSAR™ Cycle Timer (XL2015 Only)	Activates pulsed energy. Pulse width adjusts from 0.05 of a second (5% duty) to 0.95 of a second (95% duty) every second.
6.	Amplitude Control Knob	Controls the amplitude of ultrasonic vibration at the tip of the horn.
7.	Tuning Control Knob	Allows adjustment of generator frequency to optimize performance of convertor/horn assembly. Also used to verify condition of horn and/or tip.
8.	SHV Cable Connector	Connects convertor cable to generator.
9.	Footswitch Jack	Connects external ON/OFF control (Foot Switch or Timer).
10.	Power Receptacle	Connects line cord to generator.
11.	Fuse (10 amp 115V) (8 amp 220V)	Protects against electrical overload.

6. PREPARATION FOR USE

1. If the Ultrasonic Processor has been left in a very cold environment for a prolonged period of time, do not operate the unit until it has reached room temperature. Turn the power switch ON, with the Amplitude Control Knob at zero, for 20 minutes before using, to warm-up the electronics faster.
2. To safeguard the fuse against failure, always switch the power supply off before connecting or disconnecting the foot switch plug.
3. Check to make sure that the Power Switch on the generator is turned OFF.
4. Turn the Amplitude Control Knob counter clockwise to setting zero.
5. Clean the mating surfaces of the convertor and probe or stepped microtip as well as the threaded stud and hole. Check that the stud is tight. Do NOT apply grease to mating surfaces or threads of the convertor, horn, replaceable flat tip or microtip probe.
6. Connect the Power Cord to the receptacle on the rear of the generator and plug it into a grounded power outlet.
7. The horn and its flat tip were assembled and attached to the convertor at the factory, but it is recommended that you check the tightness of the horn and flat tip by using the wrenches provided and referring to 6-3 & 6-4 of this manual. An insufficiently tightened horn or tip will inhibit tuning and might cause damage to the generator circuitry or mating parts of the convertor and horn. **NEVER** assemble or disassemble the probe by holding the convertor in a vise. **ALWAYS** use the wrenches supplied with the unit.
8. Mount the convertor and horn into the sleeve on the top of the SONABOX™ Acoustic Enclosure (Part # 432B) or use the Convertor Stand and Positioner (Part # 438) to hold the convertor and horn in position. Do **NOT** hold or clamp the convertor by the front driver (black portion) or by the horn itself. Support the convertor only by clamping around the broad (chrome) section. (See 6-2)
9. Before operation, be sure to tune the system. Refer to the tuning instructions, 7-1 through 7-3, of this manual. **CAUTION!** Improper tuning can cause damage to the generator circuitry.
10. Connect either end of the coaxial HIGH FREQUENCY cable to the rear of the chassis and the other end to the receptacle on the convertor. Push the connectors in and turn the chrome rings clockwise ¼ turn to secure the connectors.
11. If a foot switch or timer switch is used, plug it into the FOOT SWITCH CONNECTOR. Make sure that the plug is inserted properly.
12. If you will be using a MICROTIP or Extender, remove the Flat Tip on the end of the horn, then attach the MICROTIP or Extender in its place. (See 6-3 & 6-4)

REMOVAL AND ATTACHMENT OF HORNS AND TIPS

To connect a horn to the convertor or a tip to a horn:

1. Thread by hand until all joints mate smoothly.
2. Tighten using wrenches as explained below, being sure to apply even and firm pressure.
3. If resistance is met, avoid cross threading and rethread by hand.
4. Do **NOT** force the threads by wrenching.

To attach or remove a horn:

1. Insert the pin of a pin spanner wrench into one of the holes at the base of the horn.
2. Insert the pin of a second pin spanner wrench into one of the holes in the front driver (black portion) of the convertor.
3. Apply even and firm pressure.

To attach or remove a Flat Tip, MICROTIP or Extender:

1. Insert the pin of a pin spanner wrench into one of the holes at the base of the horn.
2. Place the opening of the 7/16" open end wrench on the wrench flats of the Flat Tip, MICROTIP or Extender.
3. Apply even and firm pressure.

CAUTION!!

An insufficiently tightened horn, probe or tip will inhibit tuning and might cause damage to the generator circuitry or mating parts of the convertor and horn. **NEVER** assemble or disassemble the probe by holding the convertor in a vise. Always use the tools provided and place a firm mat or towel underneath the convertor and horn to prevent slippage or damage. Avoid pressing the sides of a MICROTIP or Extender down into a counter top when tightening or removing.

A loud, high piercing sound emanating from the horn or probe indicates that one of the components is loose or possibly cracked. STOP processing immediately. Turn off the generator and check the tightness of the horn to the convertor, and the tip or probe to the horn if applicable. Retune the generator and try running the unit again. If the loud noise persists, or if you have difficulty tuning the unit, then contact MISONIX for assistance.

7. TUNING INSTRUCTIONS

XL2020 TUNING INSTRUCTIONS (PROBES & HORNS)

To assure proper operation, the generator must be tuned in accordance to the following procedure each time a new probe is changed.

NOTE

- I. **The probe or microtip should not be immersed in the liquid or come in contact with the work surface when tuning.**
- II. **When operating with liquids at extreme temperatures, immerse the probe in the liquid for a few minutes, remove from the liquid and then perform the tuning procedure.**
- III. **See 7-3 for special tuning instructions for MICROTIPS™, EXTENDERS, CUP HORNS and TRAY HORNS.**

1. Turn Amplitude Control Knob (see 5-2) fully counter-clockwise to zero.
2. Press Power Switch to the ON position. The switch should be illuminated.
3. Wait until the prompt "For Tuning Procedure, Refer to Manual" appears on the LCD display, then press the **TUNE** key, and the LCD will display as follows:
Tuning - - - Probe Active .
4. Turn the Amplitude Control Knob slowly towards setting 3.
 - 4.1. Pay strong attention to the bar graph of the LCD, **STOP** turning the Amplitude Control Knob if the bar graph exceeds 70%.
 - 4.2. Rotate the Tuning Knob (see 5-2) either clockwise or counter-clockwise until the **lowest possible bar graph reading** (usually below 20%) is achieved.
5. Turn the Amplitude Control Knob slowly towards setting 6 and repeat steps 4.1 and 4.2.
6. Turn the Amplitude Control Knob slowly towards setting 10 and repeat steps 4.1 and 4.2.
7. Rotate knob toward setting 0 and observe that the bar graph is below 20% in all settings.
8. Press the **TUNE** key to end the tuning cycle.
9. Now the SONICATOR® is ready to use.

XL2010 & XL2015 TUNING INSTRUCTIONS (PROBES & HORNS)

To assure proper operation, the generator must be tuned in accordance to the following procedure each time a new probe is changed.

NOTE

I. The probe or microtip should not be immersed in the liquid or come in contact with the work surface when tuning.

II. When operating with liquids at extreme temperatures, immerse the probe in the liquid for a few minutes, remove from the liquid and then perform the tuning procedure.

III. See 7-3 for special tuning instructions for MICROTIPS™, EXTENDERS, CUP HORNS and TRAY HORNS.

1. Turn Amplitude Control Knob (see 5-4) fully counter-clockwise to zero and turn Pulsar Duty cycle to off for the Model XL2015.
2. Press Power Switch to the ON position. The switch should be illuminated.
3. Press and hold down the TUNE switch.
4. Turn the Amplitude Control Knob slowly towards setting 3.
 - 4.1. Pay strong attention to the needle of the analog power meter, **STOP** turning the Amplitude Control Knob if the bar graph exceeds 70%.
 - 4.2. Rotate the Tuning Knob (see 5-4) either clockwise or counter-clockwise until the **lowest possible power meter reading** (usually below 20%) is achieved.
5. Turn the Amplitude Control Knob slowly towards setting 6 and repeat steps 4.1 and 4.2.
6. Turn the Amplitude Control Knob slowly towards setting 10 and repeat steps 4.1 and 4.2.
7. Rotate knob toward setting 0 and observe that the bar graph is below 20% in all settings.
8. Release the TUNE switch.
9. Now the SONICATOR® is ready to use.

MICROTIP™ AND CUP HORN TUNING INSTRUCTIONS

MICROTIPS™ & EXTENDERS

1. Tuning of the horn should be done as quickly as possible. Running in air for a long period of time may damage the horn.
2. Follow steps 1 through 3 in 7-1 for XL2020 or 7-2 for XL2010 & XL2015
3. Turn the Amplitude Control Knob (see 5-2 or 5-4) slowly towards setting 1.
 - 3.1. Pay strong attention to the bar graph of the LCD on the XL2020 or the needle of the analog power meter on the XL2010 & XL2015. **STOP** turning the Amplitude Control Knob if the reading exceeds 70%.
 - 3.2. Rotate the Tuning Knob (see 5-2 or 5-4) either clockwise or counter-clockwise until the **lowest possible reading** (usually below 20%) is achieved.
4. Turn the Amplitude Control Knob slowly towards setting 3 and repeat steps 3.1 and 3.2.
5. Turn the Amplitude Control Knob slowly towards setting 5 and repeat steps 3.1 and 3.2.
6. Follow steps 7 through 9 in 7-1 for XL2020 or 7-2 for XL2010 & XL2015.

CUP HORNS & TRAY HORNS

1. Do not tune horn with liquid in the cup. Drain filled cup down to the outlet fitting level, perform the tuning procedure as outlined in 7-1 for XL2020 or 7-2 for XL2010 & XL2015, then refill the liquid to the desired level.

8. PROGRAMMING THE MICROPROCESSOR OF XL2020

REVIEW OF KEYS

<u>Key</u>	<u>Action</u>
TUNE	Activates or Deactivates tuning circuit.
<u>START</u> <u>STOP</u>	Starts or Stops output in all modes of operation. Resets timer in timed mode.
<u>PROG.</u> <u>DATA</u>	Initiates Timer and PULSAR™ entry program and displays entries on the LCD screen during run.
ENTER	Enters data during program mode.
CLEAR	Clears previous or erroneous entries. Exits programming mode.
PAUSE	Interrupts or Resumes processing cycle.

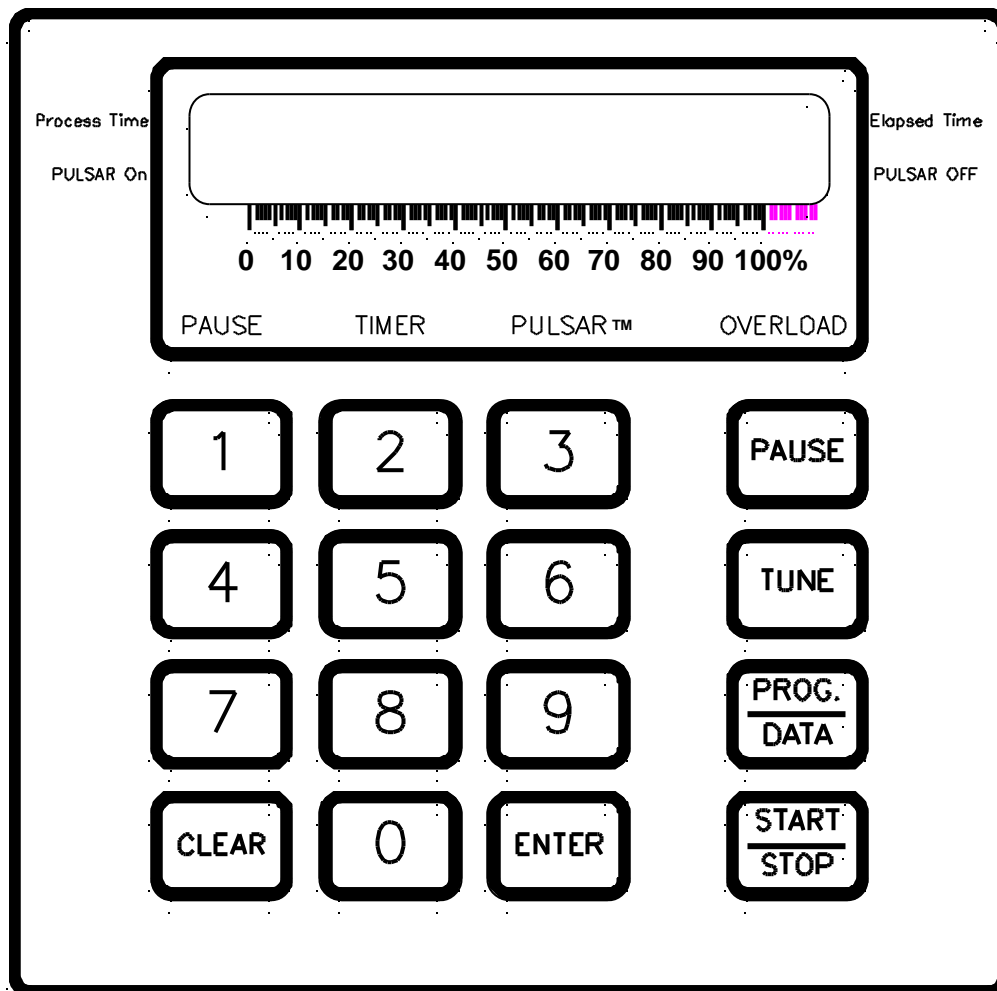

CONTINUOUS MODE

Ultrasonic energy is delivered continuously without any timing or pulsing cycles. The ultrasonic output will shut down when the total processing time reaches 9:59:59 (hr:min:sec).

Programming Steps and Descriptions	Action	LCD Display
Turn ON generator.	Press "I" on Power Switch	SONICATOR XL2020 MISONIX INCORPORATED (Scrolls on screen, then switches to) For Tuning Procedure Refer to Manual (alternates with) If SONICATOR is Tuned, Press CLEAR
Clear introduction message.	Press CLEAR Key	Press PROG to Program Timer and PULSAR or (alternates with) Press START for Continuous Operation
Start sonication in continuous mode. (Turn Amplitude Control Knob to desired level)	Press START Key STOP	Continuous 0:00:00 (Elapsed Time begins to count seconds)
To interrupt processing.	Press PAUSE Key	Continuous X:XX:XX Press PAUSE to Continue
To continue processing.	Press PAUSE Key	Continuous X:XX:XX (Timer continues to count seconds)
Stop sonication when finished.	Press START Key STOP	Press PROG to Program Timer and PULSAR or (alternates with) Press START for Continuous Operation

TIMER MODE ONLY

Ultrasonic energy is delivered continuously for a specified length of time up to 9:59:59 (hr:min:sec).

Programming Steps and Descriptions	Action	LCD Display
Turn ON generator.	Press "I" on Power Switch	SONICATOR XL2020 MISONIX INCORPORATED (Scrolls on screen, then switches to) For Tuning Procedure Refer to Manual (alternates with) If SONICATOR is Tuned, Press CLEAR
Clear introduction message.	Press CLEAR Key	Press PROG to Program Timer and PULSAR or (alternates with) Press START for Continuous Operation
Begin programming.	Press PROG. Key DATA	0:00:00 PROG, START, CLEAR 00:00.0 (MEM.0) 00:00.0
Select the default memory location (MEM.0)	Press PROG. Key DATA	0:00:00 (hr:min:sec) Enter Total Process Time (alternates with) 0:00:00 (hr:min:sec) Then Press ENTER
Enter total processing time from 00:00:01 to 9:59:59. For example: 20 minutes	Press [2] [0] [0] [0] Keys, and then press ENTER Key	Enter Pulse ON Time 00:00.0 (min:sec.tenths) (alternates with) Then Press ENTER 00:00.0 (min:sec.tenths)
Skip pulsing feature. Enter 0 for pulse ON time.	Press [0] Key, and then press ENTER Key	0:20:00 PROG, START, CLEAR 00:00.0 (MEM.0) 00:00.0
Start sonication in timed mode. (Turn Amplitude Control Knob to desired level)	Press START Key STOP	0:20:00 0:00:00 (Elapsed Time begins to count seconds)
To interrupt processing.	Press PAUSE Key	0:20:00 X:XX:XX Press PAUSE to Continue
To continue processing.	Press PAUSE Key	0:20:00 X:XX:XX (Timer continues to count seconds)
To display parameters of program.	Press PROG. Key DATA	0:20:00 hr:mn:sc X:XX:XX 00:00.0 min:sec 00:00.0 (Then switches back to) 0:20:00 X:XX:XX (Timer is always counting seconds)
To abort program.	Press START Key STOP	0:20:00 PROG, START, CLEAR 00:00.0 (MEM.0) 00:00.0
When program is completed, exit programming mode.	Press CLEAR Key	Press PROG to Program Timer and PULSAR or (alternates with) Press START for Continuous Operation

PULSAR™ MODE ONLY

Ultrasonic energy is delivered in pulsed cycles (programmable ON and OFF times), but without a specified total processing time. The range of pulse ON and OFF times can be entered from 00:00.1 to 59:59.1 (min:sec.tenths). Ultrasonic output will shut down when the total processing time reaches 9:59:59 (hr:min:sec).

Programming Steps and Descriptions	Action	LCD Display
Turn ON generator.	Press "1" on Power Switch	SONICATOR XL2020 MISONIX INCORPORATED (Scrolls on screen, then switches to) For Tuning Procedure Refer to Manual (alternates with) If SONICATOR is Tuned, Press CLEAR
Clear introduction message.	Press CLEAR Key	Press PROG to Program Timer and PULSAR or (alternates with) Press START for Continuous Operation
Begin programming.	Press PROG. Key DATA	0:00:00 PROG, START, CLEAR 00:00.0 (MEM.0) 00:00.0
Select the default memory location (MEM.0)	Press PROG. Key DATA	0:00:00 (hr:min:sec) Enter Total Process Time (alternates with) 0:00:00 (hr:min:sec) Then Press ENTER
Skip timer feature. Enter 0 for total process time.	Press [0] Key, and then press ENTER Key	Enter Pulse ON Time 00:00.0 (min:sec.tenths) (alternates with) Then Press ENTER 00:00.0 (min:sec.tenths)
Enter pulse ON time from 00:00:00.1 to 59:59:00.1. For example: 30 seconds	Press [3] [0] [0] Keys, and then press ENTER Key	Enter Pulse OFF Time (min:sec.tenths) 00:00.0 (alternates with) Then Press ENTER (min:sec.tenths) 00:00.0
Enter pulse OFF time from 00:00:00.1 to 59:59:00.1. For example: 7.5 seconds	Press [7] [5] Keys, and then press ENTER Key	0:00:00 PROG, START, CLEAR 00:30.0 (MEM.0) 00:07.5
Start sonication in pulsed mode. (Turn Amplitude Control Knob to desired level)	Press START Key STOP	Pulsing 0:00:00 (Elapsed Time begins to count seconds)
To interrupt processing.	Press PAUSE Key	X:XX:XX Press PAUSE to Continue
To continue processing.	Press PAUSE Key	X:XX:XX (Timer continues to count seconds)
To display parameters of program.	Press PROG. Key DATA	0:00:00 hr:mn:sc X:XX:XX 00:30.0 min:sec 00:07.5 (Then switches back to) X:XX:XX (Timer is always counting seconds)
To abort program.	Press START Key STOP	0:00:00 PROG, START, CLEAR 00:30.0 (MEM.0) 00:07.5
When program is completed, exit	Press CLEAR Key	Press PROG to Program

programming mode.		Timer and PULSAR or (alternates with) Press START for Continuous Operation
-------------------	--	--

TIMER AND PULSAR™ MODE

Ultrasonic energy is delivered in pulsed cycles (programmable ON and OFF times), for a specified total processing time. The range of pulse ON and OFF times can be entered from 00:00.1 to 59:59.1 (min:sec.tenths), with a maximum total processing time of 9:59:59 (hr:min:sec).

Programming Steps and Descriptions	Action	LCD Display
Turn ON generator.	Press "I" on Power Switch	SONICATOR XL2020 MISONIX INCORPORATED (Scrolls on screen, then switches to) For Tuning Procedure Refer to Manual (alternates with) If SONICATOR is Tuned, Press CLEAR
Clear introduction message.	Press CLEAR Key	Press PROG to Program Timer and PULSAR or (alternates with) Press START for Continuous Operation
Begin programming.	Press PROG. Key DATA	0:00:00 PROG, START, CLEAR 00:00.0 (MEM.0) 00:00.0
Select the default memory location (MEM.0)	Press PROG. Key DATA	0:00:00 (hr:min:sec) Enter Total Process Time (alternates with) 0:00:00 (hr:min:sec) Then Press ENTER
Enter total processing time from 00:00:01 to 9:59:59. For example: 10 minutes	Press [1] [0] [0] [0] Keys, and then press ENTER Key	Enter Pulse ON Time 00:00.0 (min:sec.tenths) (alternates with) Then Press ENTER 00:00.0 (min:sec.tenths)
Enter pulse ON time from 00:00:00.1 to 59:59:00.1. For example: 1 second	Press [1] [0] Keys, and then press ENTER Key	Enter Pulse OFF Time (min:sec.tenths) 00:00.0 (alternates with) Then Press ENTER (min:sec.tenths) 00:00.0
Enter pulse OFF time from 00:00:00.1 to 59:59:00.1. For example: 1.5 seconds	Press [1] [5] Keys, and then press ENTER Key	0:10:00 PROG, START, CLEAR 00:01.0 (MEM.0) 00:01.5
Start sonication in timed and pulsed mode. (Turn Amplitude Control Knob to desired level)	Press START Key STOP	0:10:00 Pulsing 0:00:00 (Elapsed Time begins to count seconds)
To interrupt processing.	Press PAUSE Key	0:10:00 Pulsing X:XX:XX Press PAUSE to Continue
To continue processing.	Press PAUSE Key	0:10:00 Pulsing X:XX:XX (Timer continues to count seconds)
To display parameters of program.	Press PROG. Key DATA	0:10:00 hr:mn:sc X:XX:XX 00:01.0 min:sec 00:01.5 (Then switches back to)

		0:10:00 Pulsing X:XX:XX (Timer is always counting seconds)
To abort program.	Press START Key STOP	0:10:00 PROG, START, CLEAR 00:01.0 (MEM.0) 00:01.5
When program is completed, exit programming mode.	Press CLEAR Key	Press PROG to Program Timer and PULSAR or (alternates with) Press START for Continuous Operation

STORING PROGRAMS INTO MEMORY

The microprocessor can store up to 10 reproducible set-up programs as described in 8-2 to 8-5. A stored program can be reviewed by pressing the corresponding numerical key.

Programming Steps and Descriptions	Action	LCD Display
Turn ON generator.	Press "I" on Power Switch	SONICATOR XL2020 MISONIX INCORPORATED (Scrolls on screen, then switches to) For Tuning Procedure Refer to Manual (alternates with) If SONICATOR is Tuned, Press CLEAR
Clear introduction message.	Press CLEAR Key	Press PROG to Program Timer and PULSAR or (alternates with) Press START for Continuous Operation
Begin programming.	Press PROG. Key DATA	0:00:00 PROG, START, CLEAR 00:00.0 (MEM.0) 00:00.0
Choose a memory location (0-9) to store parameters. For example: memory location 1	Press [1] Key	0:00:00 PROG, START, CLEAR 00:00.0 (MEM.1) 00:00.0
Enter parameters for your choice of mode.	Follow instructions for each mode. See 8-2 to 8-5	See instructions for each mode in 8-2 to 8-5
Review parameters at a different memory location (0-9). For example: memory location 5	Press [5] Key	X:XX:XX PROG, START, CLEAR XX:XX.X (MEM.5) XX:XX.X
Start sonication using the parameters in the displayed memory location.	Press START Key STOP	See 8-2 to 8-5 for displays during sonication in each mode.

9. ACCESSORIES

CUP HORN

Attach directly to the convertor in place of the standard horn. The Cup Horn has either a 2" or 2½" diameter radiating surface with an attached clear acrylic sleeve. The sleeve of the Cup Horn is filled with water (or other liquid) and sample vessels are placed inside. The Cup Horn is used to process multiple samples without direct probe contact, and functions much like a high intensity ultrasonic bath.

INSTALLATION

- 1) Place the rubber splash shield over the small end of the cup horn. Work the splash shield up so that it rests on the shoulder of the horn.
- 2) Hand tighten the cup horn to the convertor.
- 3) Tighten the horn with the pin spanner wrenches.
- 4) Support the convertor and cup horn in the SONABOX Acoustic Enclosure or in a lab stand using two clamps on the **convertor only**. DO NOT place a clamp at the base of the horn. This will dampen the transmission of ultrasonic energy from the convertor and will cause permanent damage to the generator.
- 5) Install fittings (plugs and/or hose adapters) to inlet, outlet and overflow ports.
- 6) Tune the system before adding water or other coolant (follow the tuning instructions outlined in 7-1 through 7-3).
- 7) When filling the cup horn, allow room for displacement when sample is added.

For constant flow cooling, use hose adapters with soft tubing. Provide pinch clamps on the Inlet and outlet tubes to control flow. An open-bath recirculating chiller is recommended for maximum cooling. The flow required is about 500 ml/min. Place a flat plate on the cup to avoid splashing if the coolant flow is turned too high.

For static cold water use, close off all three ports with the plugs provided and fill the cup. If sonication is brief, the heat generated in the cup is insignificant to affect the sample. If the water temperature rises, pour it out and refill the cup with cold water. To further lower the temperature, add crushed ice to the water. Immerse the sample vessel below the ice level so that your sample is fully exposed to the face of the horn, below the ice.

Another method of operation is to fit the outlet port with the hose adapter, soft tubing and a pinch clamp. Run the tubing, without bends or loops, directly to a drain. Add ice and water to the cup. After the ice melts, drain the cup and refill with ice and water. If the fittings leak, place TEFLON tape around the fitting threads. If coolant splashes into the shield, tip the shield's edge to drain it.

For maximum transmission of acoustic energy into a vessel, use a cavitation-resistant fluid such as a water-glycol mixture, pure ethylene or propylene glycol. The sonication intensity will be greatly increased, in proportion to the glycol concentration.

OPERATION

Most laboratory grade plastic or borosilicate glass vessels which will fit into the cup are suitable for sonication. Polystyrene and polycarbonate are the best transmitters of acoustic energy. Polypropylene and polyethylene are too soft and may be ineffective. Glassware must be free of any scratches and fully annealed or it may over stress and crack.

Ultrasonic energy is radiated directly upward through the base of the vessel while transmission through the side is negligible. For this reason, flat bottomed vessels are best and round bottomed are next best. Vessels should have thin, uniform bases, without any heavy edges or centers. Conical tubes should be tilted to expose maximum sample area to the horn. Samples should be wide and shallow, rather than high and narrow.

Maintain a small clearance around the vessel to allow adequate coolant flow. Suspend vessels at least $\frac{1}{8}$ to $\frac{1}{4}$ " (3 to 6 mm) above the face of the horn.

Energy in the cup can be determined easily by the pattern of sonication (cavitation bubbles or micro-streaming) in the coolant. At low levels, the bubbles will usually appear as a dome of bubbles capping the coolant exit in the face of the horn. As the amplitude of the horn (output control knob setting) is raised, the bubble pattern will lift and become vertical diaphanous streams in the center of the cup, sometimes forming a spider-like pattern.

OUTPUT SETTING PARAMETERS

When working with small samples there is a tendency to turn the Amplitude Control Knob too high. Doing so causes the ultrasonic energy to go around the vessel, not through it. The chart below is a good guide on selecting a power setting according to liquid sample volume. However, all samples differ and may require a slightly higher power setting according to solid content and viscosity.

<u>Sample Volume</u>	<u>Power Setting</u>
100 μ l - 500 μ l	0 - 1
500 μ l - 2 ml	1 - 2
2 ml - 5 ml	2 - 4
5 ml - 20 ml	4 - 5
20 ml - 50 ml	5 - 7
50 ml - 200 ml	7 - 8

MAINTENANCE

The cup is made of acrylic plastic and should be cleaned periodically with a mild detergent, not with abrasives or solvents. The horn is a tuned resonant body of titanium alloy. Do not attempt to resurface the horn if it shows erosion after extended use. The horn may be used as long as it can be tuned. Contact Misonix if problems occur.

CONTINUOUS FLOW CELL

Used for continuous in-line processing applications, and for batches larger than 2 liters. The smaller flow cells thread directly onto the standard horns ($\frac{1}{2}$ ", $\frac{3}{4}$ " or 1" diameter) using the threaded section on the body of the horn. The larger flow cells clamp onto specially designed Flanged Horns using quick-release clamps.

The FLOCELL™ permits continuous sonication of a flowing product. It allows the introduction of one or more constituents into an ultrasonic field in which biological cell disruption, emulsification, homogenization and other processes take place. The cell is fitted with three $\frac{1}{4}$ " NPT flow ports, two in the body and one in the orifice holder. This cell is designed to be used with an external cooling device so that temperatures can be kept as close to the freezing point of the process liquids as possible, for maximum cavitation effect. The cell includes two orifice plates drilled $\frac{1}{8}$ " and $\frac{3}{32}$ ". Flow through the cell can be controlled by the orifice size alone, or by suitable outlet valving. The metal parts (orifice plates, holder and retainer) are stainless steel and the O-rings are Buna-N (nitrile) synthetic rubber.

Transparent Polycarbonate Model (Part # 800A)

This model permits observation of the sonication process. The material of the body tube is resistant to most dilute acids and bases, oils, aliphatic hydrocarbons, ethers and alcohols. It may be attacked by strong alkalis, aromatic or halogenated hydrocarbons, or low molecular weight aldehydes. DO NOT EXCEED 50 psig PRESSURE or full power on the SONICATOR® output power meter.

Stainless Steel Model (Part # 800B)

The material of the body tube is resistant to most dilute acids and bases, oils, aliphatic hydrocarbons, ethers and alcohols. It can be attacked by strong acids. DO NOT EXCEED 100 psig PRESSURE or full power on the SONICATOR® output power meter.

1. Three $\frac{1}{4}$ " NPT hose fittings and three $\frac{1}{4}$ " NPT plugs are supplied.
2. Do not use the two body ports as both inlet and outlet.
3. Flow must be directed through the orifice.
4. Select the appropriate orifice and install it with a -014 size O-ring in the orifice holder.
5. Assemble the orifice with the stepped side away from the holder, projecting through the knurled orifice retainer.
6. Assemble a -026 size O-ring to the holder and wet the O-ring and the mating surface of the inside of the body.
7. Use care in assembling the holder to the body to prevent stripping the first threads in the body or cutting the -026 size O-ring.

8. Similarly, wet the -220 size O-ring in the other end of the body and the mating surface of the Disruptor horn and fit the body over the Disruptor horn.
9. Screw the body on the Disruptor horn until it bottoms and then back it off $\frac{1}{4}$ turn.
10. The body should not be tightened on the horn.
11. Adjust the sonication annulus by screwing the holder in or out the appropriate distance from the radiating face on the tip of the horn.
12. Connect soft plastic inlet and outlet tubing to the fittings provided, with valves as required.
13. Valves should be installed at the outer ends of the tubing to minimize the weight hanging from the horn.
14. Test the completed assembly for leakage before pressurizing.

Flow can be in either direction if only one inlet is used. It may be more advantageous to direct flow upwards through the orifice holder and out through the body fitting. Flow must be from the body toward the orifice holder if two inlets are used.

Orifice retainer and holder are stainless steel and have very fine threads shipped with a light film of machine oil to prevent galling. If the oil film is removed with the use of solvents or any other means, apply molybdenum disulfide, powdered Teflon, graphite or other appropriate lubricant.

Stainless Steel Model (Part # 800C)

1. Clean cell and all metallic parts with appropriate solution.
2. Install #228 O-ring on horn.
3. Connect horn to convertor. Tighten using pin spanner wrenches as described in 6-3 and 6-4.
4. Push horn into upper section of cell, until fully seated.
5. Place one 3" sanitary gasket on upper flange.
6. Place each half of split upper ring over gasket, checking the seating of rings on gasket.
7. Place 3" clamp around upper flange and hand tighten.
8. Thread flow tube into liquid inlet and wrench tighten.
9. Place sanitary gasket on liquid inlet and place inlet against cell, checking the seating of gasket.
10. Place 3" sanitary clamp around lower flange and hand tighten.
11. Connect cell to plumbing via $\frac{1}{2}$ " union. Connect vent line via $\frac{1}{2}$ " union.
12. Connect convertor cable to convertor and generator.
13. If cell/convertor assembly can not be supported by the inlet/outlet plumbing, a clamp around the cell may be used. If clamping both cell and convertor, DO NOT clamp in a manner which will cause misalignment on axial centerline of cell and convertor.

MICROTIP™

Attach directly to the end of the ½" diameter tapped horn in place of the flat tip. The Microtip™ Probes are tapered down to a narrow point and serve as the third stage of acoustic amplification. They are used to process small sample volumes ranging from 0.2 - 50 ml.

The MICROTIP is a precision instrument and is designed to give extreme output intensity. To obtain optimum life from this accessory, the following precautions must be observed:

1. Do not permit the MICROTIP to fall or drop on a hard surface or to bear against the work table during installation or removal.
2. The MICROTIP should never be operated in air, except to tune the unit. Tuning should not exceed 10 seconds at the MICROTIP limit (setting 5 on the Amplitude Control Knob). If tuning cannot be accomplished rapidly, reduce power to about half of the full output control position and tune again. Then check tuning at the desired power setting (below setting 5 on the Amplitude Control Knob; the MICROTIP limit).
3. Always immerse the MICROTIP in liquid before turning on the instrument. Immersing a live MICROTIP may cause splashing, aerosoling or foaming.
4. If the material being treated aerosols or foams, the generator should be turned off immediately as this is equivalent to operating the MICROTIP in air.
5. The MICROTIP must not be allowed to touch the rim or side of the processing vessel, especially close to the MICROTIP end (the radiating surface).

WARNING!!

The MICROTIP operates close to the stress limits of titanium and any of the above mentioned conditions can introduce a microscopic crack in the tip or cause it to break. The output intensity (or amplitude) of the MICROTIP probe is considerably larger than that of the standard ½" horn.

STEPPED MICROTIP™

Consists of an upper section and a lower section. The upper section is used in place of the standard horn, and the lower section attaches directly into the upper section. The lower section has 3 "steps" that narrow the probe's diameter from ½" to ". The Stepped Microtip™ is used in place of a tapered Microtip™ when a longer reach and narrower profile are required, such as when processing samples in long, narrow test tubes (e.g. 12mm x 75mm).

EXTENDER TIP

Half-Wave and Full-Wave Extenders are used to extend the length of a horn and provide longer reach when needed. Extenders attach directly to the end of any tapped horn of equal tip diameter. They are cylindrical (not tapered or stepped), and are available in lengths of 5" or 10".

When Extender Tips are used for long-duration sonication at high output settings, they may develop considerable heat. Do not allow them to exceed 140 F (60 C), and do not exceed the MICROTIP limit of 5 on the Amplitude Control Knob.

Always tune the system before using the Extender Tip. As with any combination of horns and tips, optimum operation is obtained only by tuning the generator to obtain the lowest possible output power readings. Tuning assures that the operating frequency of the generator is matched to the resonant frequency of the convertor, horn and Extender Tip. For tuning instructions see 7-1 through 7-3.

SAPPHIRE TIPPED HORN

1. Sapphire tips are thin discs of pure, water clear, boule-grown, synthetic sapphire, bonded with extremely high-shear epoxy to the radiating face of solid ultrasonic horns. Sapphire discs can not be used on removable flat tips because the wrenching forces are transmitted to the disc and cause fracture. Sapphire discs are not applied to horns under ½" (12.7 mm) in radiating face diameter.
2. Sapphire tip discs are very hard, with a rating of 9.0 on the Mohs scale (where diamond is 10). However, they are also easily fractured by mechanical shock or bending. Therefore, avoid any contact between the tip and any solid object, especially when the horn is energized.
3. A thin layer of epoxy holds the sapphire disc to the end of the horn. This epoxy is subject to cavitation erosion and leaching under strong chemical attack. Always check the condition of the bond. Visible loss of epoxy under the tip will result in eventual failure of the disc.
4. The sapphire tip generates cavitation in liquids exactly in the same manner as the titanium tips. The sapphire disc will normally last approximately 10 times longer than the regular titanium tip. Erosion appears as a matte finish on the radiating face. Eroded discs can NOT be refinished or polished.
5. Cracked, broken or eroded discs can be removed from used horns and replaced at the factory. Contact MISONIX or local representative for current replacement information.
6. Horns with broken or chipped discs should never be used. Erosion could occur on the exposed face of the horn and render it unsalvageable.
7. Be sure to store sapphire tipped horns in a safe place and well protected from impact. Ambient temperatures and humidity will not damage the disc or epoxy.

SONABOX

Before unpacking or assembling, please READ THESE INSTRUCTIONS carefully. See 9-8.

Unpack by grasping the Enclosure body to lift from carton. DO NOT lift by latch assembly (door handle). Open SONABOX by lifting latch handle to the horizontal position and turning handle 90° in either direction. Remove and unwrap two Z-shaped legs with two rubber feet attached to each leg.

For Standard Horn or Microtip Assembly

Remove the four screws from the convertor neck, invert neck with cylindrical sleeve outward, and reinstall screws.

For Cup Horns

Remove four screws at corners of box. Place Z-shaped legs on box and reinstall screws. If fitting coolant tubing to cup horn, remove two screws from Z-strip, reverse Z-strip to uncover three holes, and reinstall screws. Pass coolant tubing through holes. Invert Enclosure.

If the Acoustic Enclosure is to be used exclusively with the cup horn, the latch handle may be reversed to close downward. Remove inner nut which secures pawl. DO NOT allow adjusting (outer) nut to rotate. Remove pawl, rotate it 180° on shaft, reinstall pawl and nut, and tighten nut.

DUAL HORN

The Dual Horn accessory allows a single SONICATOR® to process two samples simultaneously. Full power is delivered to two 3/4" diameter solid stepped extenders, which vibrate at the same intensity as a single 3/4" horn. EPA specifications, such as in Method SW846-3550, are met for power output, probe size and intensity.

TRAY HORN

The Tray Horn is designed to provide ultrasonic energy to all the wells in a single polystyrene or polypropylene microplate. It attaches directly to the convertor in place of the standard horn. There is a rectangular radiating surface with an attached clear acrylic sleeve. The sleeve of the Tray Horn is filled with water (or other liquid) and microplates are placed inside. The Tray Horn works just like a Cup Horn, only larger and custom designed for microplates. (See Cup Horn 9-1 through 9-3)

10. TROUBLESHOOTING

WARNING: To avoid electric shock, do not remove the case cover from the Generator. There are no user-serviceable parts inside this device.

OVERLOAD INDICATOR INSTRUCTIONS

All SONICATOR® XL Series generators are designed to deliver high power to the convertor/horn assembly on a continuous basis. However, under certain extraordinary conditions, the amount of power supplied might endanger the circuitry to the point of failure.

In order to prevent equipment failure, an overload protection feature has been built into the XL Series generators. When the output power exceeds design specifications, the overload light will illuminate on all models and the output will be disabled. On Model XL2020, the following prompt will appear on the LCD display in addition to the indicator light: "OVERLOAD REFER TO MANUAL". When overload occurs for all models, proceed with steps 1 - 7 below:

1. Shut the unit off using main power switch.
2. Check all electrical connections.
3. Eliminate contact between horn and sample. For flow cell applications, reduce static pressure if necessary.
4. Check tightness of horns and/or tips. Remove tips and clean threads before tightening.
5. Check horn for cracks or excessive erosion.
6. Turn on SONICATOR® and follow tuning instructions. If horn/tip cannot be tuned, replace and tune again.
7. If all preceding fails to rectify problem, consult Misonix, Inc.

TROUBLESHOOTING GUIDE

SYMPTOM	POSSIBLE CAUSE	REMEDIAL ACTION
System does not turn on	Power Cord not connected	Check Power Cord
System does not turn on	Power Outlet off	Check wall socket for voltage
System does not turn on	Blown line fuse(s)	Replace fuse(s)
System can not be tuned	Loose Probe or Tip	Tighten with supplied wrenches
System can not be tuned	Broken/Worn Probe or Tip	Replace Probe or Tip
System is on, but there is no output	Convertor and/or cable disconnected	Check all electrical connections
System is on, but there is no output	Blown Transistors	Send Unit in for service

11. MAINTENANCE

GENERAL MAINTENANCE

It is recommended to periodically inspect the unit, both visually and physically, to insure optimum and safe performance. This inspection should be scheduled as a routine maintenance procedure, done with the SONICATOR® in the OFF position, and with the unit unplugged from the AC power source.

Long exposure to acids or caustics results in corrosion of metal parts or components. Check the rear of the generator, convertor, and cables for any signs of rust or discoloration. If discoloration is found, move the SONICATOR® away from the source of the contaminant.

Examine the condition of the high voltage cable which attaches the convertor to the generator. Inspect the wire insulation for damage, such as wear, burning from hot plate contact or breakage from extended use or rough handling.

Inspect the cable connectors by gently pulling on the wire while holding the metal portion of the connector. The cable connectors and rubber boot protectors at both ends of the cable should be tight to the wire, with no movement possible and no cracks or frayed ends visible. Do not subject the cable ends to severe bending loads while performing these tests. Order a replacement cable immediately if your cable does not pass the above inspection. Should the convertor/cable assembly be subjected to misuse, such as dropping or a severe pulling force on the wire itself, the cable must be inspected as above.

DO NOT USE A CABLE WITH BROKEN END CONNECTIONS, EXPOSED WIRES OR FRAYED INSULATION. HIGH VOLTAGE IS PRESENT IN THE CABLE AND MAY POSE A SHOCK HAZARD. DO NOT TOUCH THE CONVERTOR ASSEMBLY UNTIL THE POWER SWITCH OF THE GENERATOR IS OFF AND THE UNIT IS UNPLUGGED.

In general use, the cable assembly should not be used to carry the convertor or pull it toward the user. Make certain the cable always has slack and is never tensioned. Move the generator or convertor assembly closer to one another to accomplish this. If this is not possible, contact Misonix to obtain a longer cable.

Should the SONICATOR® stop functioning or if it cannot be tuned, shut the unit off and inspect the cable as above **BEFORE** any other action is taken.

If the operator is in doubt as to the condition of the unit, call 800-645-9846 to speak with a customer service representative for prompt attention.

CLEANING INSTRUCTIONS

The generator and convertor may be cleaned using an acid-free cleaning solution (i.e. glass cleaner). Horns and probes should be cleaned using isopropyl alcohol.

TIP CARE

The probe tip may be sterilized either by immersing in boiling water or in a detergent bactericide and a disinfectant.

Before each experiment, and after tuning, place the probe tip in water or alcohol and turn the power on for a few seconds to remove residue. The tip also can be sterilized using alcohol with the power on. Proper handling precautions must be taken while sterilizing with alcohol.

The sides and end of the tip must NEVER be allowed to come in contact with anything but the solution. When using a microtip, the stress resulting at the point of contact with the vessel could cause the microtip to fracture. Standard probes will not fracture if they come in contact with the vessel, but can damage the vessel.

Touching the vessel wall with the tip will release tiny glass and titanium particles into the sample which may gray the solution. The particles will form a thin dark gray layer on centrifuging but usually have an insignificant effect chemically.

Proper care of the probe is essential for dependable service. The intense cavitation will, after a prolonged period, cause the tip to erode, and decrease the efficiency of the sonication process without showing up on the power monitor. The smoother and more polished the tip, the more power will be transmitted into the liquid. Any erosion of the probe tip will increase the rate of future erosion. For that reason, it is recommended that after every 5 or 6 hours of use, the tip be examined, and if necessary, polished with a fine emery cloth. Since the probe and tip are tuned to vibrate at a specific frequency, it is most important that only the contaminated surface be removed. If tip or horn is excessively eroded, replace the tip or horn as in instructions in 6-3 & 6-4. When changing the tip, check for wear in all mating surfaces. If the horn itself is worn or damaged, replace the horn as well. Retune the generator to the probe whenever a probe or tip is replaced.

12. APPLICATIONS

PRINCIPLES OF ULTRASONICS

The generator (power supply) converts conventional 50/60 Hz AC line power to 20 kHz electrical energy which is fed to the convertor where it is transformed to mechanical vibration. The heart of the convertor is a piezoelectric crystal which, when subjected to an alternating voltage, expands and contracts. The convertor vibrates in the longitudinal direction and transmits this motion to the horn tip immersed in the liquid solution. Cavitation results, in which microscopic vapor bubbles are formed momentarily and implode, causing powerful shock waves to radiate throughout the sample from the tip face. Horns and MICROTIP probes amplify the longitudinal vibration of the convertor; higher amplification (or gain) results in more intense cavitation action and greater disruption. The larger the tip of the probe, the larger the volume that can be processed but at a lesser intensity.

The convertor is tuned to vibrate at a fixed frequency of 20 kHz. All horns and MICROTIP probes are resonant bodies, and are also tuned to vibrate at 20 kHz. Intense cavitation after a prolonged period will cause the tip of the horns and MICROTIP probes to erode. Erosion will cause a slight variation in frequency. It is important that the probe is retuned by following the tuning procedure in 7-1 through 7-3.

The SONICATOR® Ultrasonic Liquid Processor will break down cells, bacteria, spores or tissue. It can prepare an emulsion down to 1/100 of a micron, homogenize immiscible liquids, polymerize some materials, de-polymerize others, and accelerate chemical reactions. By virtue of this instrument, faster and more efficient extraction of serums, toxins, enzymes, and viruses from organic sources is also made possible. Cavitation breaks down cell structure rapidly, allowing the desired material to pass into the processing medium before the cell contents undergo any substantial chemical change. It also does an excellent job of degassing.

PROCESSING TISSUE

Whenever possible, the tissue should be diced very small to permit movement within the liquid. Freezing followed by powdering could also be used, if this procedure is not detrimental to the experiment.

Large samples should first be liquefied in a high speed mechanical blender for about 10 seconds. If sub-cellular particles are desired intact, the amplitude control should be set low and the processing time increased.

Since the greatest concentration of energy is immediately below the probe, it is imperative that the sample be kept as close to the tip as possible. Liquids are easily processed because the free moving cells circulate repeatedly below the probe. Solid materials, however, have a tendency to be repelled by the ultrasonic action. To alleviate this problem, the vessel should be large enough to accommodate the probe, yet small enough to restrict sample movement.

If the probe has to come in contact with a solid sample, use a standard 3/4" (20mm) diameter stainless steel centrifuge tube cut to 3" (70mm) length. Do NOT use a glass tube.

PROCESSING DIFFICULT CELLS

When processing difficult cells, the use of enzymes should be considered. Glusulase can be used with yeast, lysostaphin can be used with staphylococcus, collagenase can be used with skin and cartilage, and trypsin hyaluronidase can be used with liver and kidney. Glass beads in the 10 to 50 micron size range can also be added to the liquid to expedite processing. When using glass beads, a good ratio is beads, liquid. Glass beads concentrate the energy released by the implosion and facilitate the crushing of cell walls. After processing, the glass will sink to the bottom of the vessel or can be centrifuged or filtered out.

For further application information see section 16 (Literature Request).

13. TECHNIQUES

PROBE DEPTH

Immerse the probe tip not less than 1 to 1½ times the tip diameters into the solution, without touching the bottom. This depth rate applies to the ½" horn; immersion depth can be less for larger horns and may have to be more for smaller probes used at higher intensity.

FOAMING AND AEROSOLING

Insert the tip deep enough below the surface of the liquid to insure there is no aerosoling or foaming. Aerosoling and foaming generally occur when the tip is not immersed far enough into the solution. Lowering the power and increasing sonication time will usually reduce aerosoling; in severe cases, use an aerosol cap or sealed atmosphere treatment chamber. In organic materials, protein release from cell material acts like a wetting agent and tends to promote foaming. Lowering the tip in the solution, increasing power, and reducing solution temperature will normally prevent foaming. For severe foaming:

- Use a narrower processing vessel
- Use a vessel with an irregular inner surface
- Increase effective viscosity by concentration or by adding glass beads.

Once foaming occurs, shut off power or reduce it below cavitation level before proceeding. It may be necessary to use a centrifuge or high vacuum to reduce a tenacious foam. If foam persists, the sample may have to be discarded.

VISCOSITY LIMITATIONS

Viscous solutions and highly concentrated liquids can be difficult to sonicate. If the liquid is so thick that it will not pour or circulate easily, or if 25 micron glass powder will not settle to the bottom quickly, it is too thick and cannot be processed effectively.

KEEPING SAMPLES COOL

Intense ultrasonic processing causes the liquid temperature to elevate especially with small volumes. Since high temperature reduces cavitation, the liquid should be kept as cold as possible. This can be accomplished by immersing the sample vessel in an ice-salt-water-alcohol bath, or by using a water-jacketed processing vessel through which very cold water or alcohol is circulated. To minimize temperature elevation, use the PULSAR™ Cycle Timer or pulse manually in short, quick bursts.

FREE RADICAL FORMATION

Trace free radicals produced by ultrasonics will usually have little or no enzyme activity. The free radicals may be H₂O₂, O₃ as well as many other molecules and ions produced from air or water. If this kind of reaction is suspected, it can easily be avoided by using CO₂ or N₂ atmosphere. A CO₂ atmosphere is quickly obtained by placing a pellet of dry ice in the solution before processing and let it "bubble out". A CO₂ atmosphere stops luminescence in the cavitation bubble for the same reason it prevents it in a vacuum tube. It is this luminescence which causes the water and air molecules to break up producing the radicals. This CO₂ procedure, as simple as it is, again is ordinarily unnecessary.

14. **WARRANTY**

The generator and convertor of all SONICATOR® Ultrasonic Liquid Processor devices and accessory equipment manufactured by MISONIX, Incorporated are unconditionally warranted for a period of two years from the date of original delivery.

Horns, Tips and Microtip™ probes are warranted against defects in material and workmanship, under normal use in accordance with written instructions, for a period of two years from the date of original delivery.

The obligation of MISONIX Incorporated under this guaranty will be to make any repair at its plant in Farmingdale, New York, or at any of its designated service centers, without charge, including parts and labor, but not including shipping charges, necessitated by any defect in workmanship or material.

This guarantee is in lieu of any warranty of any kind or nature including fitness for any particular application under that Uniform Commercial Code or any other statute, regulation, court decision, or otherwise. MISONIX Incorporated shall not be responsible for nay consequential damages.

This warranty shall not apply to equipment subjected to misuse, alteration, improper installation, neglect, or accident, nor to wear, erosion, or other degradation which may occur in normal use.

15. RETURN OF EQUIPMENT

All request for repairs and replacement parts should be directed to the Customer Service Department at Misonix, following the outlined procedure below.

1. Call Customer Service (1-800-645-9846) to obtain a Return Material Authorization Number.
2. Be prepared to provide the serial numbers of all applicable parts.
3. When sending in equipment, always include the generator, convertor and all horns and probes. Equipment should always be sent in the original packaging.

CAUTION!!

When original packaging is not available, be sure to wrap the convertor and generator separately in plastic bags, film, or other protective wrapping when using loose packing materials such as foam pellets, shredded paper, or excelsior. Remove MICROTIP probes or extenders and pack separately in same carton.

IMPORTANT NOTICE

BY RETURNING ANY MATERIAL TO MISONIX INC., THE CUSTOMER OR THE CUSTOMER'S AGENT THUS CERTIFIES THAT ANY AND ALL MATERIALS SO RETURNED ARE, OR HAVE BEEN RENDERED, FREE OF ANY HAZARDOUS OR NOXIOUS MATTER OR RADIOACTIVE CONTAMINATION AND ARE SAFE FOR HANDLING UNDER NORMAL REPAIR SHOP CONDITIONS. DO NOT RETURN ANY MATERIAL FOR WHICH SUCH CERTIFICATION CAN NOT BE MADE WITHOUT PRIOR APPROVAL FROM MISONIX, INC.

The correct return address should read as follows:

Misonix Incorporated
RMA # _____
1938 New Highway
Farmingdale, NY 11735 (USA)
Attn: Repair Department

Misonix Incorporated can be easily contacted by several convenient means:

Telephone: 800-645-9846
631-694-9555
Fax: 631-694-9412
E-mail: sales@misonix.com

16. LITERATURE REQUEST

Available from Misonix is descriptive material on ultrasonic liquid processing. To order, place a check next to the title you wish to receive. (Quantity limit is one copy per title)

BIBLIOGRAPHIES:

- BIB-1 Action of Ultrasonics on Living Tissue
- BIB-2 Ultrasonic Action on Proteins, Polysaccharides, Nucleic acids, and Lipoproteins
- BIB-3 Background Paper on Ultrasonic Dispersion
- BIB-4 Ultrasonic Emulsification in Biological Materials
- BIB-5 Action of Ultrasonics on Polymers - General Research
- BIB-6 Effect of Sonication on NMR Spectra of Biological Materials
- BIB-7 Ultrasonic Extraction of Biological Materials
- BIB-8 Application of Ultrasonics in Geology and Earth Sciences
- BIB-9 Ultrasound and Disinfection
- BIB-10 Ultrasonics and Liposomes
- BIB-11 Sonochemistry - Ultrasonic Cavitation and Chemical Reactions
- BIB-12 Suslick Bibliography on Sonochemistry
- BIB-13 Biological Research Update
- BIB-14 Ceramics and Soils Research Update
- BIB-15 Industrial Applications Update
- BIB-16 Food Technology Update

APPLICATION NOTES:

- AN-1 Breaking the Heat Barrier
- AN-2 Disrupting Tough Tissue
- AN-3 The Tissue Issue
- AN-4 Pitfalls
- AN-5 Disruption Techniques - Yeast – Chlorella
- AN-6 Cup Horn Sonication
- AN-7 Ultrasonic Degassing of Liquids
- AN-8 Reduce Cavitation Noise
- AN-9 Booster Horns
- AN-10 Continuous In-line Processing
- AN-11 Microplate Sonication
- AN-12 Shearing DNA/RNA
- AN-13 Ultrasonics and Fine Particles
- AN-14 Ultrasonic Probes in Emulsions and Fuel Research
- AN-15 Explosion Resistance and Isolation
- AN-16 Focused Ultrasonic Cleaning
- AN-17 Anti-Contamination
- AN-18 EPA Method SW846-3550
- AN-19 Sonochemistry
- AN-20 Dual Horn
- AN-21 Micro Cup Horn
- AN-22 Microtube Holders

PUBLISHED PAPERS:

- [] RPT-I "Probe Ultrasonics: Increased Productivity and Accelerated Reactions in the Modern Laboratory", AMERICAN LABORATORY NEWS
- [] RPT-II "New Methods in Ultrasonic Disruption", AMERICAN LABORATORY
- [] RPT-III "Application of an Ultrasonic Probe" (Ultrasonic Power vs. Intensity in Sonication), AMERICAN BIOTECHNOLOGY LABORATORY

TECHNICAL NOTES:

- [] TN-1 Amplitude Measurement
- [] TN-2 Extenders and Sapphire Tips
- [] TN-3 Extending Control Range
- [] TN-4 Microtips
- [] TN-5 Half-Wave Length Extender Tips
- [] TN-6 Flow Cells
- [] TN-7 Development of Protocols

TECHNICAL BULLETINS:

- [] TB-1 Ultrasound, Hearing and Health
- [] TB-3 Sifting Solids
- [] TB-4 Pulsed Sonication
- [] TB-5 ASTM Test Method G-32

Mail Request To:

MISONIX, INCORPORATED
Literature Request
1938 New Highway
Farmingdale, NY 11735

Ship Literature To:

Name: _____
Company: _____
Address: _____

City: _____
State, Zip: _____
Telephone: _____
Fax: _____

Please print clearly the exact address to which you wish the literature shipped. Thank you.

XL2010 & XL2015 CONTROLS AND INDICATORS DIAGRAM

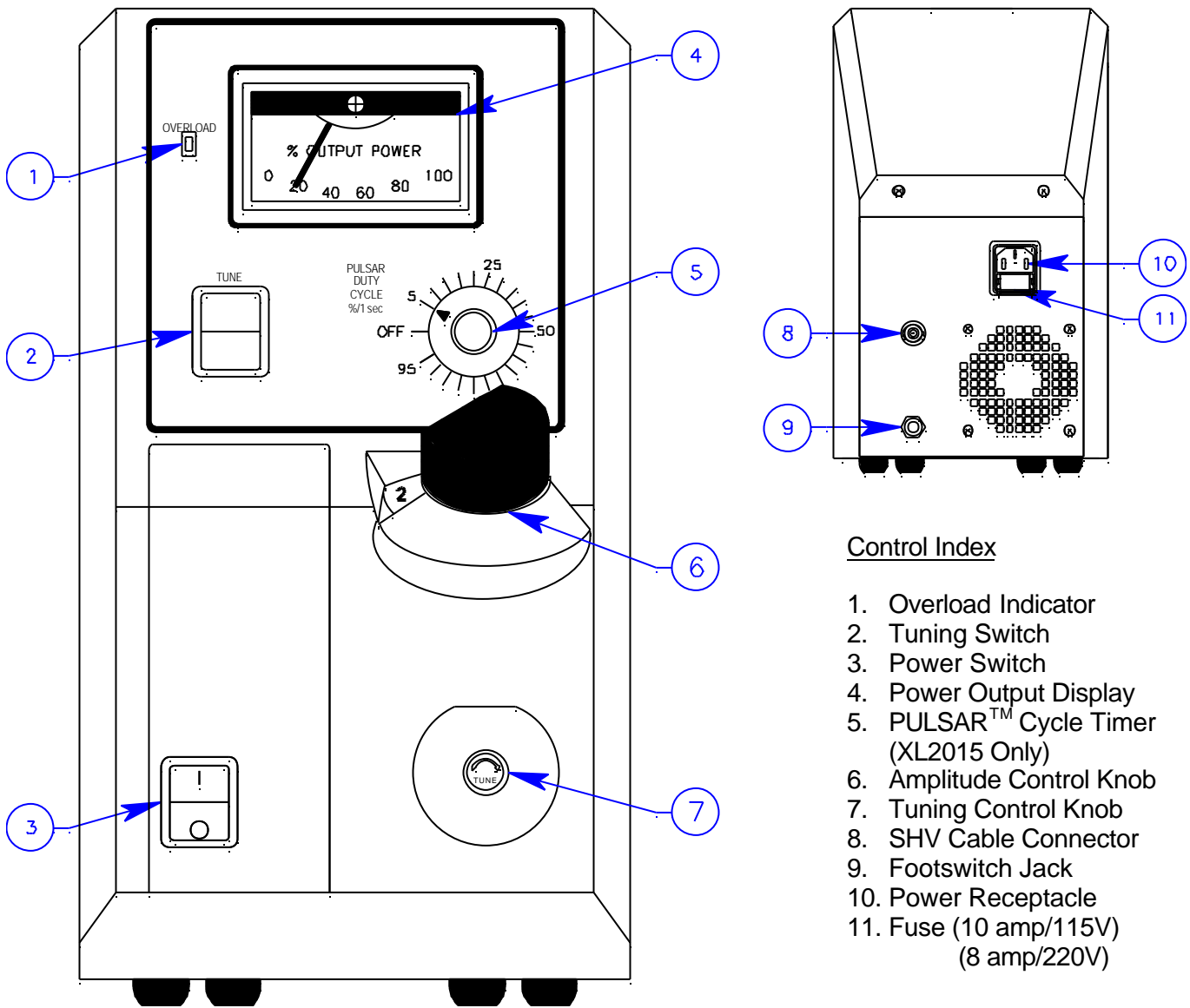

Control Index

- 1. Overload Indicator
- 2. Tuning Switch
- 3. Power Switch
- 4. Power Output Display
- 5. PULSAR™ Cycle Timer (XL2015 Only)
- 6. Amplitude Control Knob
- 7. Tuning Control Knob
- 8. SHV Cable Connector
- 9. Footswitch Jack
- 10. Power Receptacle
- 11. Fuse (10 amp/115V)
(8 amp/220V)

XL2020 CONTROLS AND INDICATORS DIAGRAM

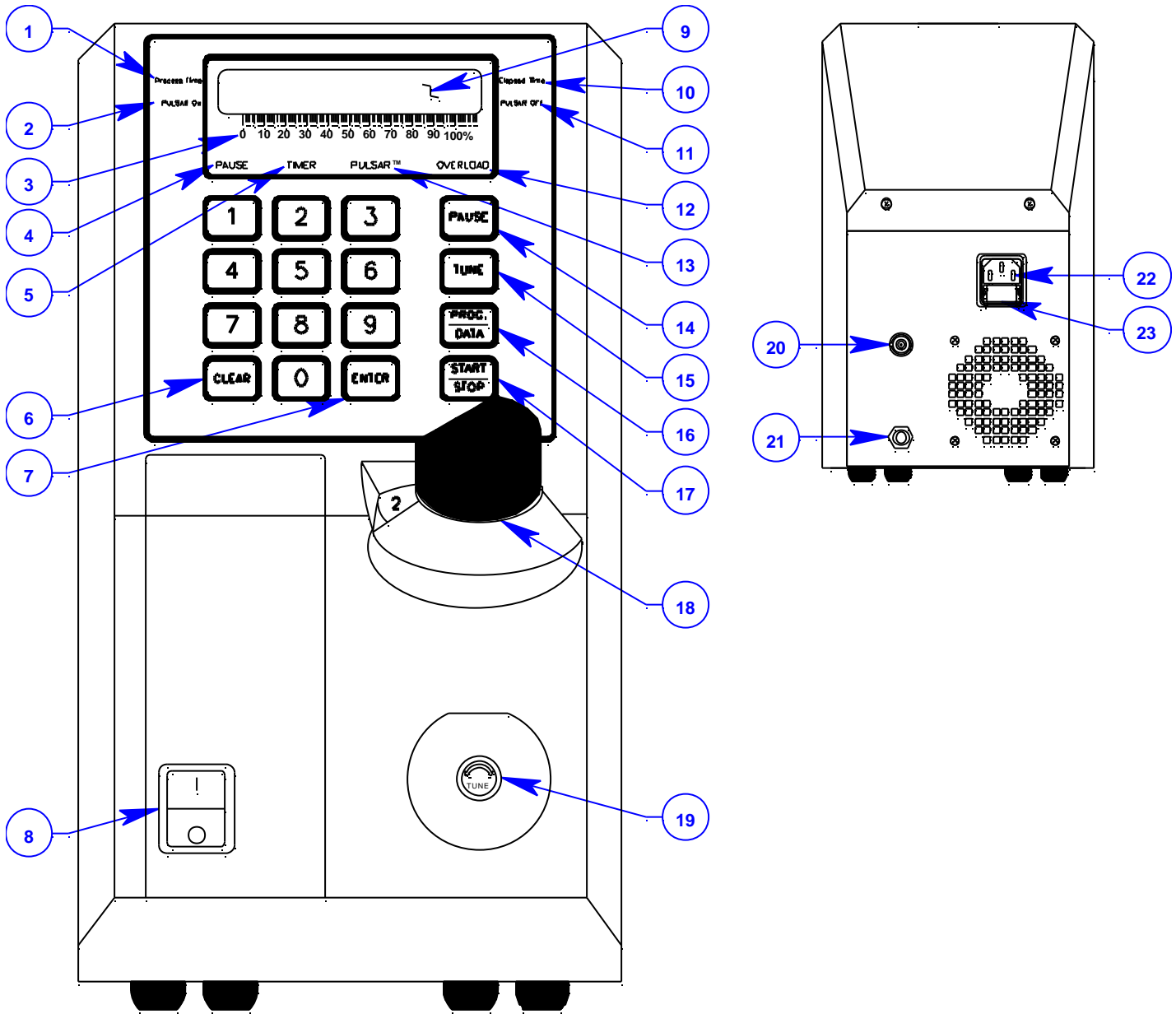

Control Index

- | | | |
|-------------------------|--------------------------|----------------------------|
| 1. Process Time | 9. LCD Display Screen | 17. START/STOP Key |
| 2. PULSAR™ On Time | 10. Elapsed Time Display | 18. Amplitude Control Knob |
| 3. Power Output Display | 11. PULSAR™ Off Time | 19. Tuning Control Knob |
| 4. Pause Indicator | 12. Overload Indicator | 20. SHV Cable Connector |
| 5. Timer Indicator | 13. PULSAR™ Indicator | 21. Footswitch Jack |
| 6. CLEAR Key | 14. PAUSE Key | 22. Power Receptacle |
| 7. ENTER Key | 15. TUNE Key | 23. Fuse (10 amp/115V) |
| 8. Power Switch | 16. PROG./DATA Key | (8 amp/220V) |

CONVERTOR MOUNTING DIAGRAM

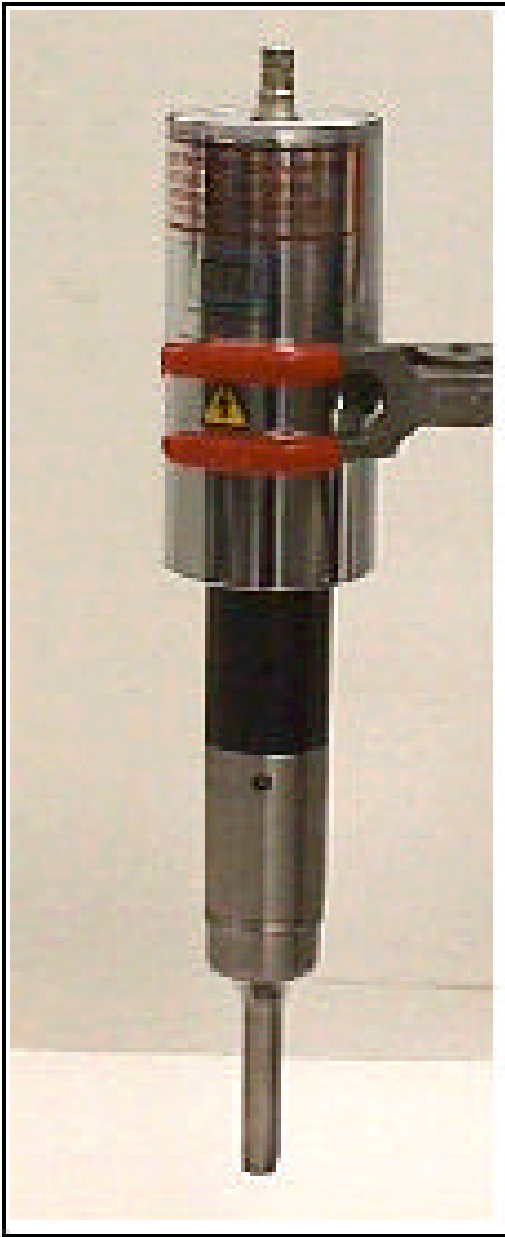

CORRECT



INCORRECT

SONABOX DIAGRAM

SUPER SONABOX ASSEMBLY FOR STANDARD HORNS

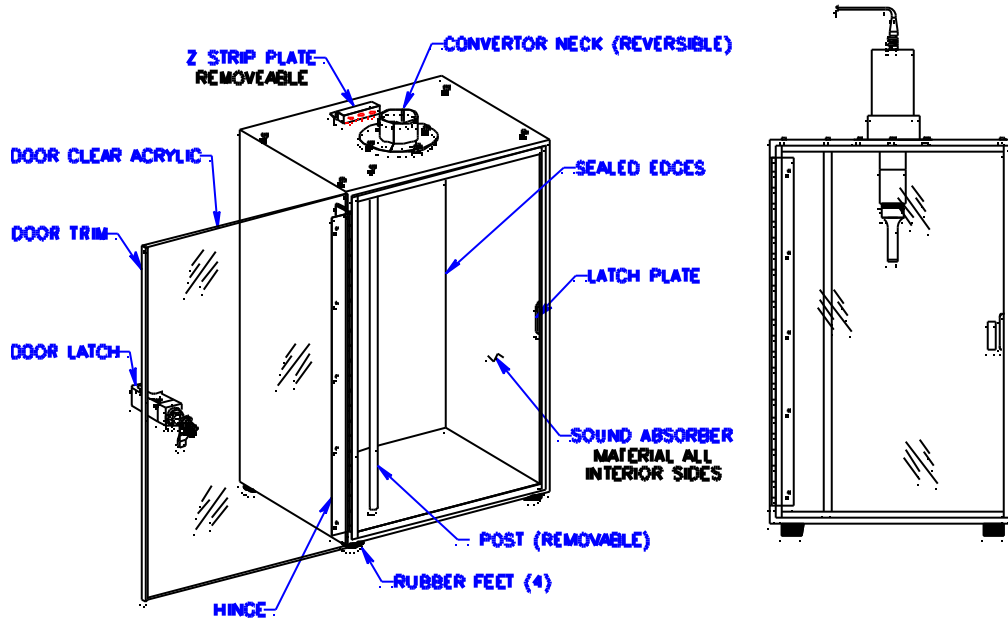

SUPER SONABOX ASSEMBLY FOR CUP HORN USE

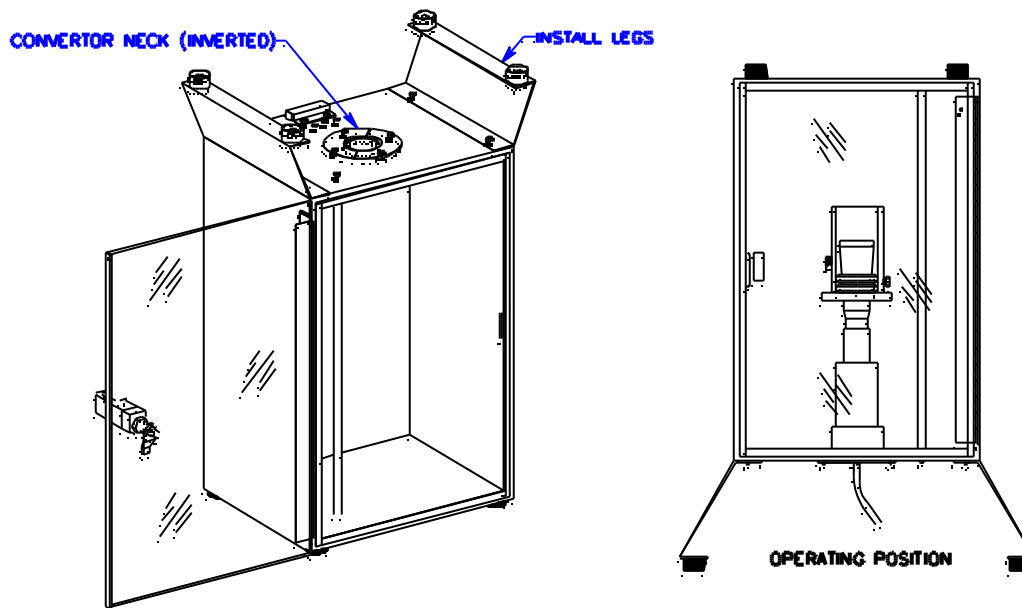

SYSTEM COMPONENTS DIAGRAM

1. Operating Manual
2. High Frequency Cable
3. 7/16" X 1/2" Open End Wrench
4. Generator
5. Converter
6. Power Cord
7. (2) Pin Spanner Wrenches
8. 1/2" Removable Flat Tip
9. 1/2" Tip Diameter Horn

REMOVAL AND ATTACHMENT OF HORNS AND TIPS DIAGRAM

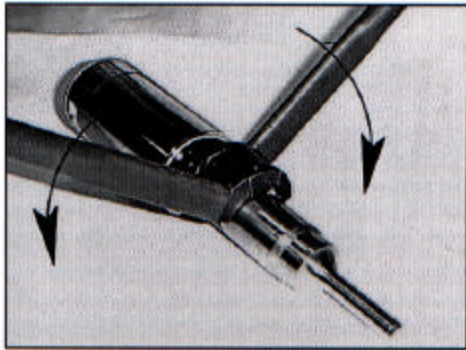

Horn Removal

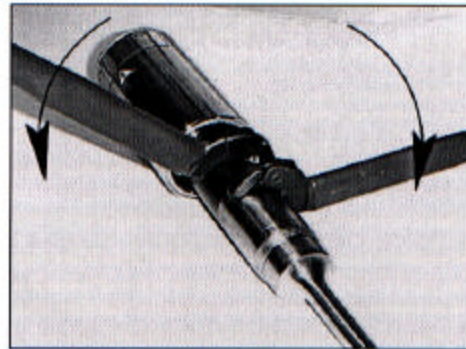

Horn Attachment

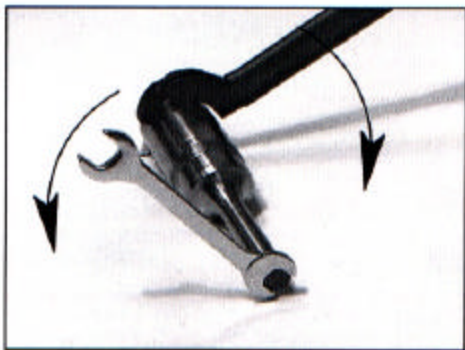

Tip Removal

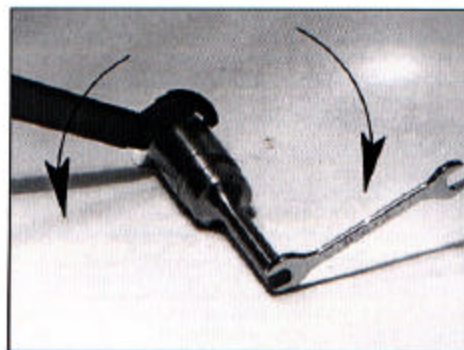

Tip Attachment

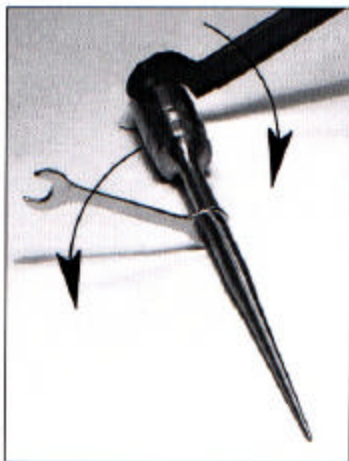

Microtip Removal

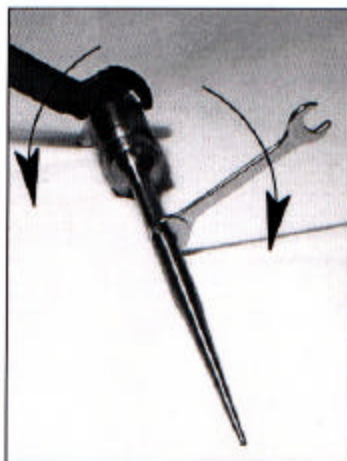

Microtip Attachment



(1) 7/16" X 1/2" Open End
(2) Pin Spanner Wrenches